



INSTRUMENTARIUM

Orthopantomograph® OP30



Digital panoramic imaging system

**Orthopantomograph® OP30**



1951



1961

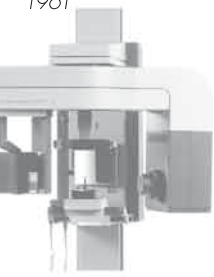

1964



1984



1992



2006



2009



2011

# Leading the way through the decades



- 1946 Professor Y.V. Paatero publishes his first paper on Panoramic Tomography.
- 1951 "Pantomography" equipment is presented.
- 1961 The first dental panoramic X-ray, the Orthopantomograph® OP1, is developed.
- 1964 Commercialization of the Orthopantomograph® begins with models OP2 and OP3.
- 1978 Orthopantomograph® becomes the leading name within dental panoramic imaging with the models OP5/ OC5, OP6 and OP10/OC10.
- 1992 New innovations, such as the lifting cassette head and linear tomography, are introduced along with the OP100 product family.
- 1999 Direct digital Orthopantomograph® OP100 product family is introduced.
- 2006 New Orthopantomograph® product family OP200 is launched.
- 2007 Volumetric Tomography (VT) is developed to maximize the performance of an Orthopantomograph® unit.
- 2009 A new member to the Orthopantomograph® product family – the OP30 – is launched.
- 2011 Orthopantomograph® OP300, the most comprehensive 3-in-1 platform is launched to celebrate 50 years of Orthopantomograph® success.

## Choose your own Orthopantomograph®

	OP30	OP200	OP300
Standard panoramic	●		
Advanced panoramic		● ●	● ●
TMJ imaging	●	● ●	● ●
Volumetric Tomography		● ●	
CB3D			● ●
Cephalometric		● ●	● ●





# D Design and quality

The Orthopantomograph® OP30 is a digital panoramic X-ray unit designed for every dental office and small imaging centers demanding a top quality digital panoramic system at a competitive price. The OP30 truly continues the legacy of the well-known Orthopantomograph® product family.

## **A standard panoramic system does not mean standard design.**

The Orthopantomograph® OP30 combines distinctive design and reliable quality with professional tools for standard panoramic imaging needs.

# It could not be easier

Straightforward operation makes panoramic imaging fast and easy. An integrated 5.7 inch touch screen with remarkably user-friendly navigation is extremely simple to use.

## Just 2 selections need to be made from the control panel:

1. Choose the imaging program
2. Use the pre-set kV values or adjust, if needed

## Patient positioning

The 5-point, easy patient positioning system holds the patient still during the imaging procedure to reduce movement artifacts. Three laser positioning lights make positioning accurate. The sharp layer is easily adjustable for every patient.



Easy wheelchair accessibility.

# One-of-a-kind image quality

The quality of images is a result of many elements, such as carefully designed features, sufficient technical characteristics and correct patient positioning. The Orthopantomograph® OP30 combines all these for your benefit and provides you with perfect images.

## All the essentials included

- ✓ Stable 5-point patient positioning
- ✓ Optimal imaging geometry
- ✓ Adjustable anterior layer position with 3 positioning lights
- ✓ High frequency tube head design
- ✓ High resolution CCD imaging sensor
- ✓ V-shaped collimation optimizes image quality
- ✓ Versatile software tools to enhance diagnostic capabilities



### Benefits of V-shaped collimation

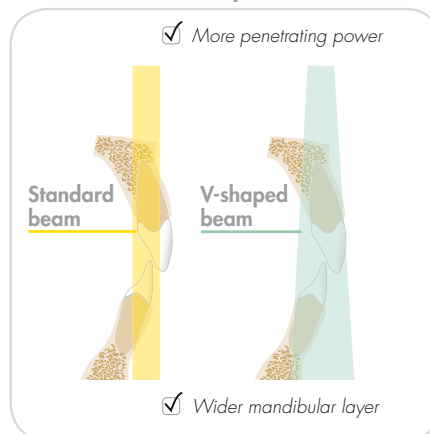

*A V-shaped beam supports better imaging of the human anatomy than a standard beam and ensures a homogeneous image.*

# Imaging programs

## Standard panoramic

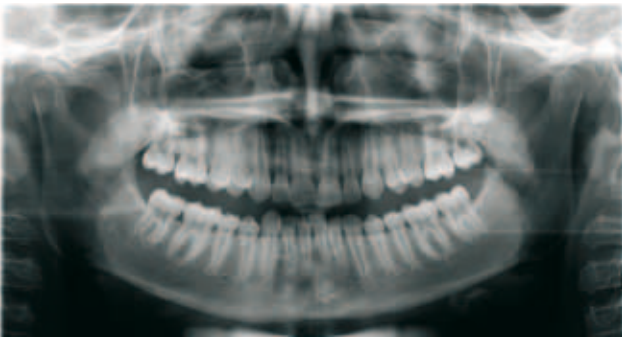

P1

The standard panoramic imaging program provides clear definition of the dental anatomy including TMJ's – only in 10 seconds.

## Pediatric panoramic

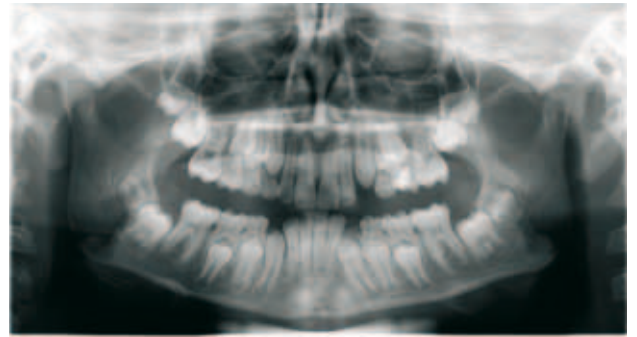

P2

The pediatric panoramic imaging program provides a reduced imaging area for pediatric and small patients.

## TMJ

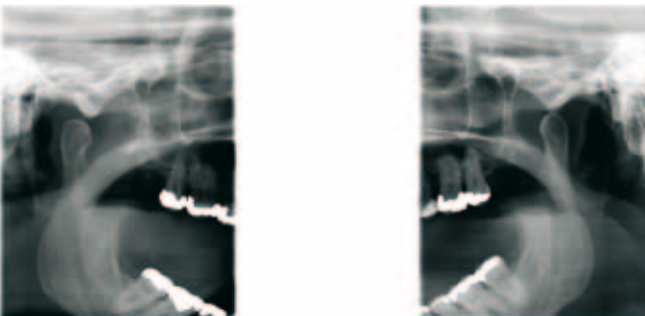

P3

Lateral view from tempomandibular joint area with mouth closed or open.

## BW

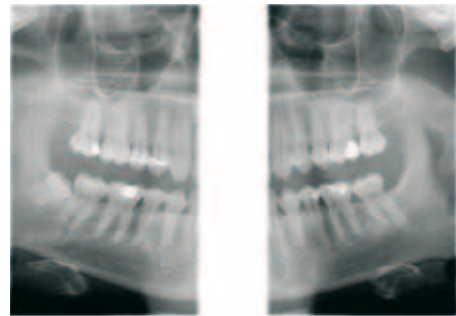

BW

The bitewing view is a quick and easy alternative for intraoral bitewing imaging.

# D Dimensions

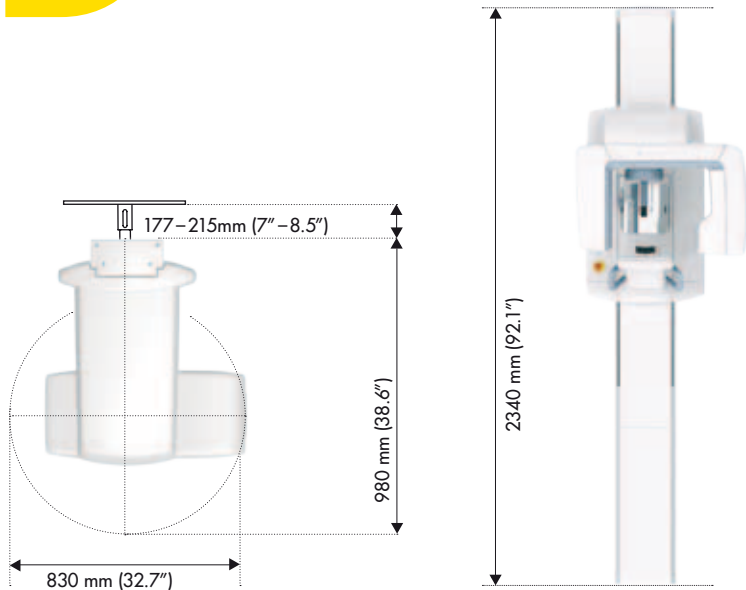

Standard column	2340 mm (92.1")
Short column	2250 mm (88.6")

# T Technical specifications

generator	High frequency DC, operating frequency 100–130kHz
X-ray tube	D-054 SB or equivalent
focal spot	0.5mm IEC 60336/1993
filtration	min 2.8 mm Al
tube voltage	66–77 kV
tube current	9/10 mA (tube current 9 mA when nominal voltage 100/115 VAC is used)
nominal voltage	100/115 VAC or 220/230/240 VAC 50/60 Hz
weight	120 kg
sensor pixel size	48 µm
image pixel size	96 µm
image field height	147 mm
PC minimum requirements for image capturing	Pentium 1 Ghz or equivalent, 512 Mb, 40 Gb
TWAIN connectivity	optional
DICOM* compatibility	optional
PC connection	LAN/Ethernet

\* DICOM is the registered trademark of the National Electrical Manufacturers Association for its standards publications relating to digital communications of medical information.



**INSTRUMENTARIUM DENTAL** develops, manufactures and markets high-tech systems and solutions for dental and maxillo-facial imaging. We work in close co-operation with dental professionals, universities and other research centers in our quest to develop solutions that will meet and exceed the expectations of our customers. As the establisher of panoramic X-ray imaging we are committed to providing high clinical performance while still maintaining simplicity, ease of use and workflow efficiency.

The Instrumentarium Dental product portfolio consists of a full range of premium quality imaging solutions for both intraoral and extraoral imaging. For more detailed information about our products please visit [www.instrumentariumdental.com](http://www.instrumentariumdental.com).

Instrumentarium Dental reserves the right to make changes to specifications and features shown herein, or to discontinue the product described at any time without notice or obligation. Contact your Instrumentarium Dental representative for the most current information. CE marked according to Medical Device Directive (NB 0537). Electrical safety according to IEC 60601-1. Operations comply with ISO 13485:2003, ISO 9001:2008, and ISO 14001:2004.

[www.instrumentariumdental.com](http://www.instrumentariumdental.com)

## Headquarters

Instrumentarium Dental  
Nahkelantie 160  
P.O.Box 20  
FI-04301 Tuusula  
Finland  
Tel. +358 10 270 2000  
Fax +358 10 270 2230

## USA

Instrumentarium Dental Inc.  
1245 W. Canal Street  
Milwaukee, Wisconsin 53233  
U.S.A  
Tel. +1 800 558 6120  
Fax +1 414 481 8665

© 2011 Instrumentarium Dental  
2055722